

KENRICH PRODUCTS

OWNERS MANUAL

MODEL GP-3A AIR GROUT PUMP

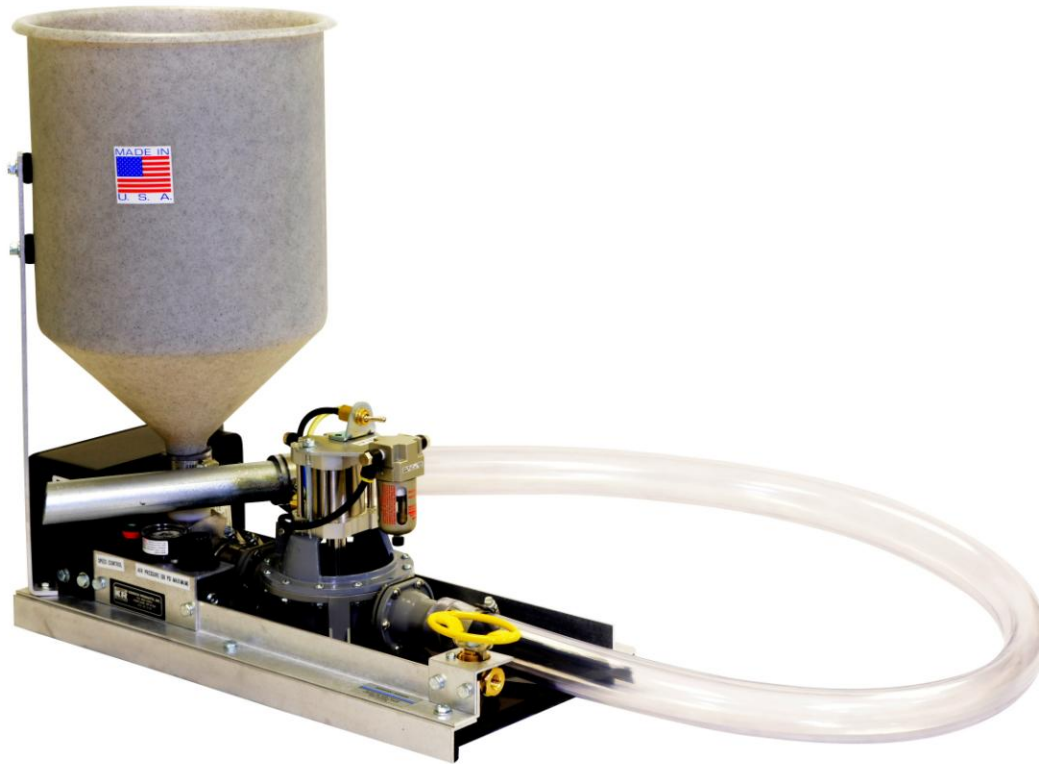

DESCRIPTION
OPERATION
MAINTENANCE
SERVICE
REPAIR PARTS

Table of Contents

Safety Warning	1
Limited Warranty	1
Description of Product	2
Applications	2
Options	2
Specifications	3
Operating Instructions	4
Performance Recommendations	5
Cleaning & Maintenance	5
Troubleshooting Guide	6
Service Instructions	7
Diaphragm Replacement	7
Flapper Valve Replacement	7
Repair Parts Lists & Illustrations	8-19
Pneumatic Components (GP-3A)	10
Pneumatic Components (GP-3AR)	10
Baseboard Group	11-12
Hopper Group	13-14
Pump Assembly	15-16
Cylinder/ Clamp Ring Assembly	17
Placement Hoses	18
Hose Reducer Kits	18
1 ½" Hose Ends & Ports Seals	19

Safety Warning

Before you begin using your Kenrich Grout Pump, carefully read and understand this owners manual. It contains important information regarding safety, operation, service and maintenance. If you should have any questions regarding the performance or operation of this product, please call (503) 281-6190 for assistance

SAFETY WARNING

Before you begin using your Kenrich Grout Pump, carefully read and understand this owner's manual. It contains important information regarding safety, operation, service and maintenance. If you should have any questions regarding the performance or operation of this product, please call (503) 281- 6190 assistance.

LIMITED WARRANTY

- 1) DURATION:
Three months (90 days) from date of purchase by the original purchaser.
- 2) WHO GIVES THIS WARRANTY
- 3) (WARRANTOR): Kenrich Products, Inc.
16327 NE Cameron Blvd.
Portland, OR 97230
Tel: (503) 281-6190 Fax: (503) 281-6227
- 4) WHO RECEIVES THIS WARRANTY (PURCHASER):
The original purchaser (other than for purposes of resale) of this Kenrich product.
- 5) WHAT IS COVERED UNDER THIS WARRANTY:
Defects in material and workmanship which occur within the duration of the warranty period.
- 6) WHAT IS NOT COVERED UNDER THIS WARRANTY:
A- IMPLIED WARRANTIES:, INCLUDING THOSE OF MERCHANTABILITY AND FITNESS FOR A PARTICULAR PURPOSE. Some states do not allow limitations on how long an implied warranty last, so the above limitations may not apply to you.
B- ANY INCIDENTAL, INDIRECT, OR CONSEQUENTIAL LOSS, DAMAGE OR EXPENSE THAT MAY RESULT FROM ANY DEFECT, FAILURE, MALFUNCTION OF A KENRICH PRODUCT.
Some states do not allow
Exclusion limitation of incidental or consequential damages so the above limitations or exclusion may not apply to you.
C- Any failure that result from an accident, purchaser's abuse, neglect or failure to operate the product in accordance with the instructions provided in the owner's manual supplied with the product.
D- Items or service that are normally required to maintain the product (i. e. diaphragms and flapper valves).
- 7) RESPONSIBILITIES OF WARRANTOR UNDER THIS WARRANTY:
Repair or replace, at Warrantor's option, products or components which have failed within the duration of the warranty period.
- 8) RESPONSIBILITIES OF PURCHASER UNDER THIS WARRANTY:
A) Deliver or ship the Kenrich product direct to Kenrich Products at address listed above. Freight cost, if any, must be borne by the purchaser.
B) Use reasonable care in the operation and maintenance of the product as described in the owner's manual.

This Limited Warranty gives you specific legal rights and you may also have other rights which vary from State to State.

DESCRIPTION OF PRODUCT

The Kenrich model GP-3A is a air-operated single diaphragm pump. It is designed to pump most types of water based grouts (not for chemical based epoxy grouts). This pump works for grouting hollow metal door frames in frames as well as placing grout anywhere that high pressure is not required.

A pneumatic cylinder is used to move the diaphragm up and down. When the cylinder retracts, the diaphragm draws the grout mixture through the open intake flapper valve into the pump. When the cylinder extends, the grout movement causes the intake flapper valve to close while opening to outlet flapper valve. This forces the grout mixture from the pump into the placement hose where it is directed to the work area.

APPLICATIONS

Filling hollow concrete block walls.

Grouting metal door and window frames in place. Hollow areas under machine bed plates.

Filling voids.

Placing grout anywhere that high pressure is not required.

OPTIONS

Hose Reducer Kits	¾" and 1" ID available
1 ½ " Hose Ends	Straight, 90° and 180° Elbows, 180 J
1 ½ " ID Hose Lengths	10 feet, 15 feet, 20 feet, and 50 feet
Port Seal	Rubber, will fit 1 ½" Hose Ends

SPECIFICATIONS

Model	GP-3A Air pump
Pump Type	Single Diaphragm, Self-Priming
Power Source	Compressed Air, 50 psi minimum
Air Consumption	No Less than 3 cfm
Pump Controls	Start/Stop switch, Speed Control, Air pressure regulator & Gauge
*Output Capacity	5 gallons per minute
Output Pressure	15 PSI Maximum
Output Pressure	Zero to 15 psi
Hopper Capacity	.62 cubic foot (5 gallons)
Placement Hose Size	1 ½ " ID by 60" long, Clear Vinyl
Discharge Head	10 foot Vertical Lift
Dimensions	23 ½ " x 12" x 23" high
Net Weight	27 pounds

*Output and performance will vary depending on cycle rate, viscosity of the grout mixture and pressure conditions.

OPERATING INSTRUCTIONS

- 1) Some grouts are more difficult (or impossible) to pump than others. Read the performance recommendations and troubleshooting guide. (See page 7&8)
- 2) Check that the “ball valve” (yellow oval handle) and the “stop/start switch” (brass switch on top of cylinder) are both turned to “off” position.
- 3) Attach an air source from your compressor to the “ball valve”.
- 4) The “pressure control” is the yellow round knob. Turn clockwise to increase pressure, counterclockwise to decrease pressure. Normal operating pressure is 30psi.
Never adjust pressure above 50 psi to avoid damage to pump. As a reference, grout line pressure is approximately 1/3rd of what is shown on the air gauge (i.e. 30psi on gauge would indicate 10 psi grout line pressure). If air pressure is adjusted below 20 psi, pump will not cycle.
- 5) The “speed control” is a black knob with a red ring. Turning it clockwise will slow the cycle speed, counterclockwise speeds the cycle speed. It is a good idea to start to pump slowly, then increase the cycle speed after the grout has started to flow from the end of the placement hose.
- 6) With the air supply hose connected and the “Ball valve” turned on, the pump can then be started and stopped from the “stop/start” switch on top of the air
- 7) Place grout in a suitable container and mix per manufacturer’s instructions. Pour the mixed grout mixture into the hopper. Though usually not required, some grouts are easier to start pumping if the pump is first primed with a cement/water slurry.
- 8) Start pump using the “stop/start” switch. Adjust pressure and speed controls as required.
Caution: Very minimal pressure is required to fill voids with grout.
- 9) Be sure that work area being filled is vented to allow any trapped air to escape.
- 10) Do not allow grout to harden or set up while inside or on the outside of the pump and related components.(See page 7&8)
- 11) This pump designed to pump most types of water based grouts. It is not to be used to pump chemical epoxy grouts.
- 12) When servicing the pump, be sure remove the air supply hose and turn off the “ball valve” to depressurize the system. Follow service instructions as required.

PERFORMANCE RECOMMENDATIONS

- 1) Always use the shortest length of placement hose as possible. The ideal length is five feet long. When grouting metal door frames, place the pump on a cart or platform. This raises the pump to a better working height and allows the use of the standard five foot long placement hose.
- 2) Always use the largest diameter hose that access will allow. The ideal size is 1 ½" inside diameter. **Never use a "rubber" based hose.**
- 3) If limited access requires that you must use hose reducer kit (either 3/4" kit #5034 or 1" kit #5083), remember that this reduction in hose size requires that air cylinder must cycle at a much slower rate.
- 4) It is always recommended that a good quality pre-packaged non-shrink grout be used. These products contain additives to help the grout pump and flow easier.
- 5) If you are mixing your own grout (sand/cement/water), the mixture will usually require additional cement in order to keep the sand in suspension. When pumping "homemade" grout, extra time will be required to find the exact proportions of sand/cement/water to achieve a pump able mixture. Adding a plasticizer to the mixture will be beneficial.

CLEANING & MAINTENANCE INSTRUCTIONS

- 1) Keep all interior and exterior surfaces of your Kenrich grout pump clean.
- 2) Immediately after use, flush the inside of the pump by filling the hopper with clean water while at the same time operating the pump. Continue until the water discharged through the placement hose is clear.
- 3) Rinse off all exterior surfaces with clean water until clean.
- 4) To prevent air and/or grout leakage, periodically check all pump screws and hose clamps for tightness. Always tighten screws evenly.
- 5) Check and drain as necessary any water trapped in air filter.
- 6) Be sure that any water trapped in the pump is drained out before winter storage to prevent damage caused from freezing.

TROUBLESHOOTING GUIDE

PROBLEM	CAUSES	CORRECTIONS
Pump will not cycle when empty	<ol style="list-style-type: none"> 1.Lack of air supply. 2.Ball Valve in "off" position 3.Start/Stop switch in "off" position. 	<ol style="list-style-type: none"> 1.Check air compressor and air line connection. 2.Turn valve to "on" position. 3.Flip switch to "on" position.
Pump will not draw the grout mixture into the pump	<ol style="list-style-type: none"> 1.Grout mixture is too thick. 2.Hole in diaphragm. 3.Incorrect installation or worn flapper valve(s). 	<ol style="list-style-type: none"> 1.Add water and/or cement to grout mixture. Can also prime pump with a cement/water slurry. 2. Replace diaphragm 3.check for correct installation and/or replace damaged valves.
Pump draws grout on up stroke, returns grout back into hopper on the down stroke of cylinder	<ol style="list-style-type: none"> 1.Damaged inlet flapper valve 	<ol style="list-style-type: none"> 1.Inspect and replace inlet flapper valve as required.
Pumps water OK but will not pump grout mixture.	<ol style="list-style-type: none"> 1.Grout mixture is too thick. 2.Aggregate size too large. 	<ol style="list-style-type: none"> 1.Add water and/or cement to grout mixture. Can also prime pump with a cement/water slurry. 2.Use smaller aggregate and/or screen out larger pieces.
Grout mixture leakage	<ol style="list-style-type: none"> 1.Loose screws that attach clamp ring, inlet & outlet flanges to pump body. 2.Cracked pump body. 3.Hole in diaphragm. 4.Loose hose clamps. 	<ol style="list-style-type: none"> 1.Check and tighten screws as necessary. 2. Check and replace as necessary. 3.Replace diaphragm. 4. Tighten hose clamp(s)

SERVICE INSTRUCTIONS

DIAPHRAGM REPLACEMENT

- 1) Loosen hose clamp and remove grout placement hose if still attached.
- 2) Remove 10 clamp ring attaching screws (item #2) and lift off the cylinder/clamp ring/ diaphragm assembly (item #1) and set it down on its side as shown in picture.
- 3) Remove the diaphragm retaining screw (item #8) and lift off lower button (item #5) and metal washer (item #7) and set aside. Remove and discard the old diaphragm (item #6).
- 4) Install new diaphragm (item #6) as shown in illustration. Reuse the button and washer (item #5 and #7) as shown. Attach retaining screw (item #8), check that all parts are properly aligned and tighten screw.
- 5) Place cylinder/clamp ring/diaphragm assembly (item #1) onto the pump body (item #9) being careful to align rib on diaphragm into groove in pump body. Install ten clamp ring attaching screws (item #2), attach hex nuts (item #140 and tighten evenly.
- 6) Attach grout placement hose if desired and tighten hose clamp.

FLAPPER VALVE REPLACEMENT

- 1) Loosen hose clamp and remove grout placement hose if still attached.
- 2) Remove 10 clamp ring attaching screws (item #2) and lift off the cylinder/clamp ring/ diaphragm assembly (item #1) and set it down on its side as shown in picture.
- 3) Remove the four cap screws (item #18), loosen hose clamp (item#17) that is closest to the pump, then remove the pump body assembly.
- 4) Remove twelve screws (item #13) from both the inlet flange (item #12) and outlet flange (item #11), then remove and discard both flapper valves (item #10).
- 5) Install new flapper valves (item #10) as shown in illustration. Finish assembly in reverse order of disassembly. Tighten flange mounting screws evenly. Note: position the new flapper valves carefully noting the direction and location of valve pivot point as shown in illustration.
- 6) Attach grout placement hose if desired and tighten hose clamp.

SERVICE INSTRUCTIONS

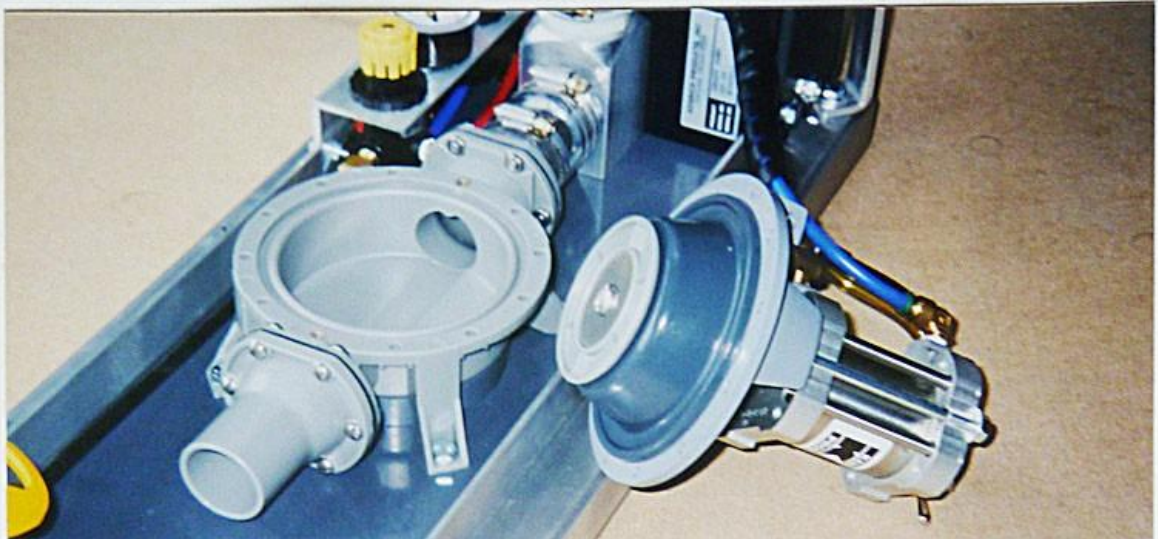
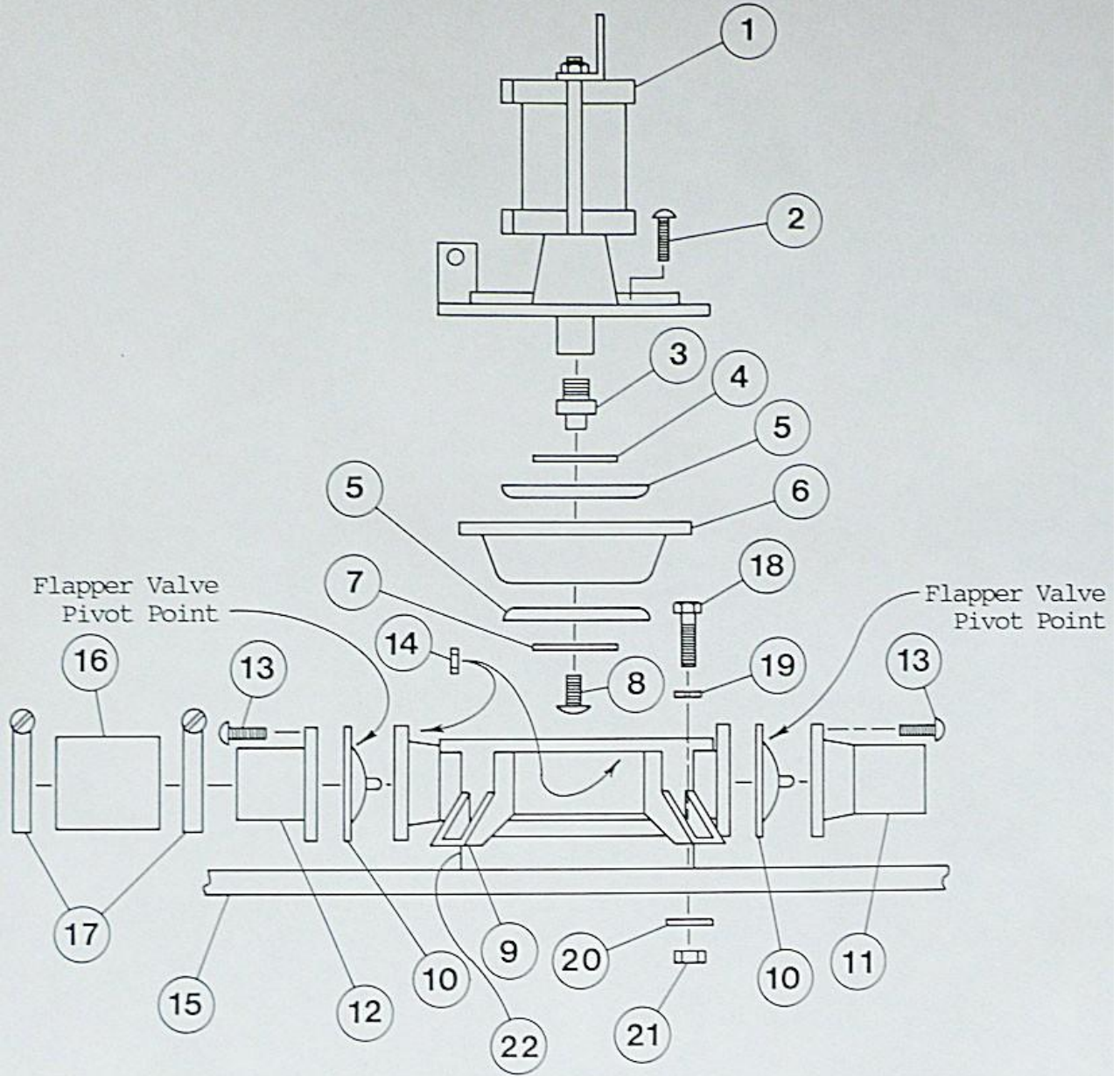

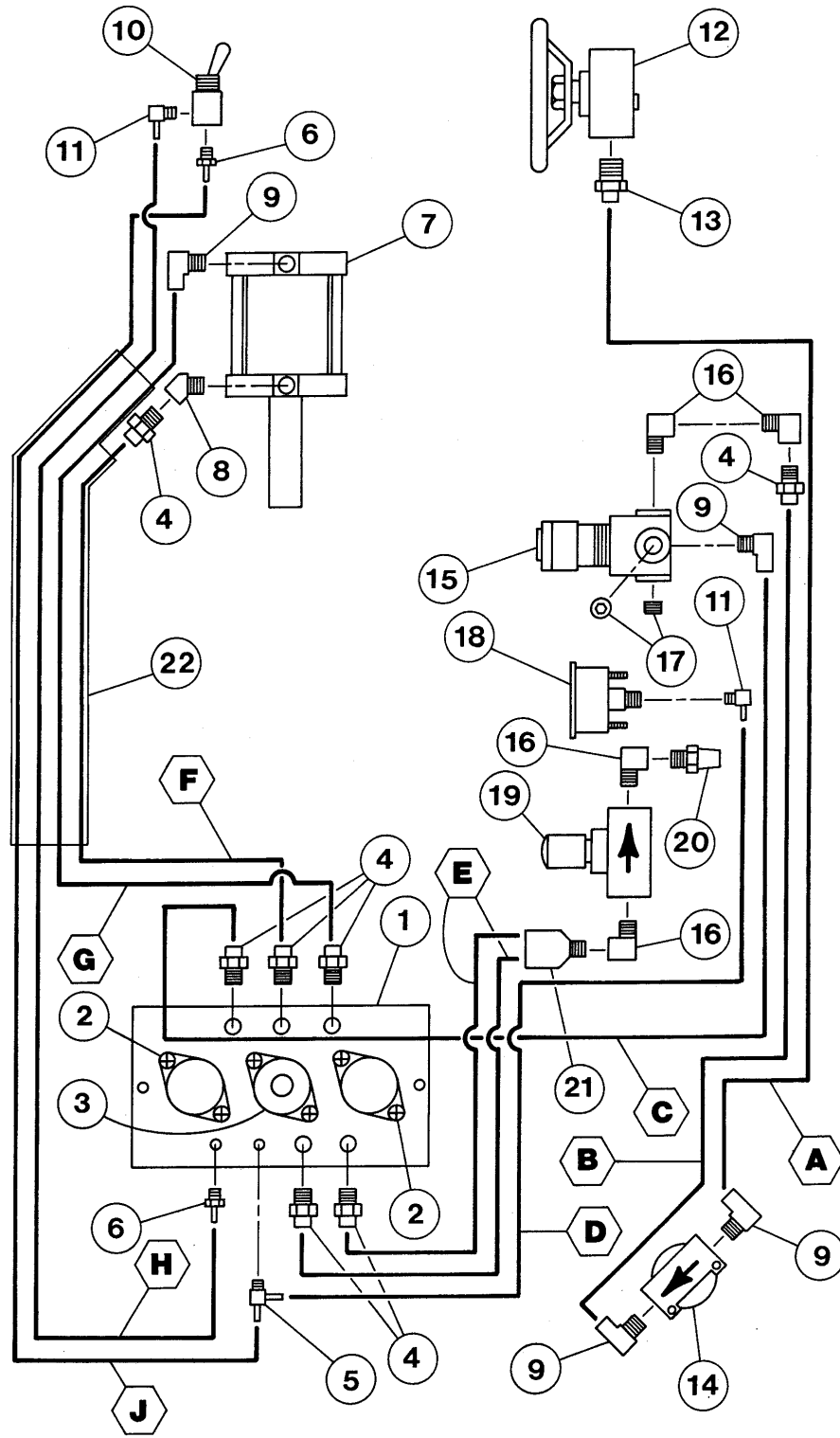

PNEUMATIC COMPONENTS

<u>ITEM</u>	<u>REQUIRED</u>	<u>PART NUMBER</u>	<u>DESCRIPTION</u>
--	1	5207	Block/Valve/Fittings Assembly, item 1 thru 6
1	1	5178	Acrylic Pneumatic Logic Block
1-1	2	1498-0150	Slotted Machine Screw, logic block mounting
1-2	2	1472	Lockwasher
1-3	2	1453	Machine Hex Nut
2	2	5180	3-Way Solenoid Valve
3	1	5179	4-Way Solenoid Valve
4	7	3310	Brass Fitting, straight prestoloc
5	1	3326	Nickel "T" Fitting
6	2	3307	Brass Fitting, straight
7	1	5198	Air Cylinder Assembly
8	1	3319	Brass Fitting, 45° pipe elbow
9	4	3323	Brass Fitting, 90° prestoloc
10	1	5181	Stop/Start Switch
11	2	3320	Nickel Fitting, 90°
12	1	5191	Ball Valve, yellow oval handle
12-1	2	1498-0037	Slotted Machine Screw, ball valve mounting
12-2	2	1472	Lockwasher
13	1	3324	Brass Fitting, straight prestoloc
14	1	5201	Air Filter
14-1	2	1498-0037	Slotted Machine Screw, air filter mounting
14-2	2	1472	Lockwasher
15	1	5189	Air Pressure Regulator
15-1	1	5202	Mounting Nut, air regulator
16	4	3321	Brass Fitting, 90° pipe elbow
17	2	3100	Pipe Plug
18	1	5187	Air Gauge
18-1	2	1450	Machine Hex Nut, air gauge mounting
18-2	2	1350	SAE Flatwasher
18-3	2	1472	Lockwasher
19	1	5184	Speed Control Valve
19-1	1	5185	Mounting Nut, speed control
20	1	5186	Exhaust Muffler
21	1	3322	Nickel "Y" Fitting, prestoloc
22	1	5206-1400	Spiral Hose Wrap, 14" long

TUBING & HOSES

A	1	2260-2600	1/4" Tubing, ball valve to filter, 26" long, black
B	1	2261-1600	1/4" Tubing, filter to regulator, 16" long, blue
C	1	2262-1300	1/4" Tubing, regulator to block, 13" long, red
D	1	2270-0850	1/8" Hose, air gauge to block, 8 1/2" long, black
E	2	2260-0700	1/4" Tubing, speed control to block, 7" long, black
F	1	2262-1200	1/4" Tubing, block to air cylinder, 12" long, red
G	1	2261-1500	1/4" Tubing, block to air cylinder, 15" long, blue
H	1	2272-1800	1/8" Hose, block to start switch, 18" long, yellow
J	1	2270-1800	1/8" Hose, block to start switch, 18" long, black

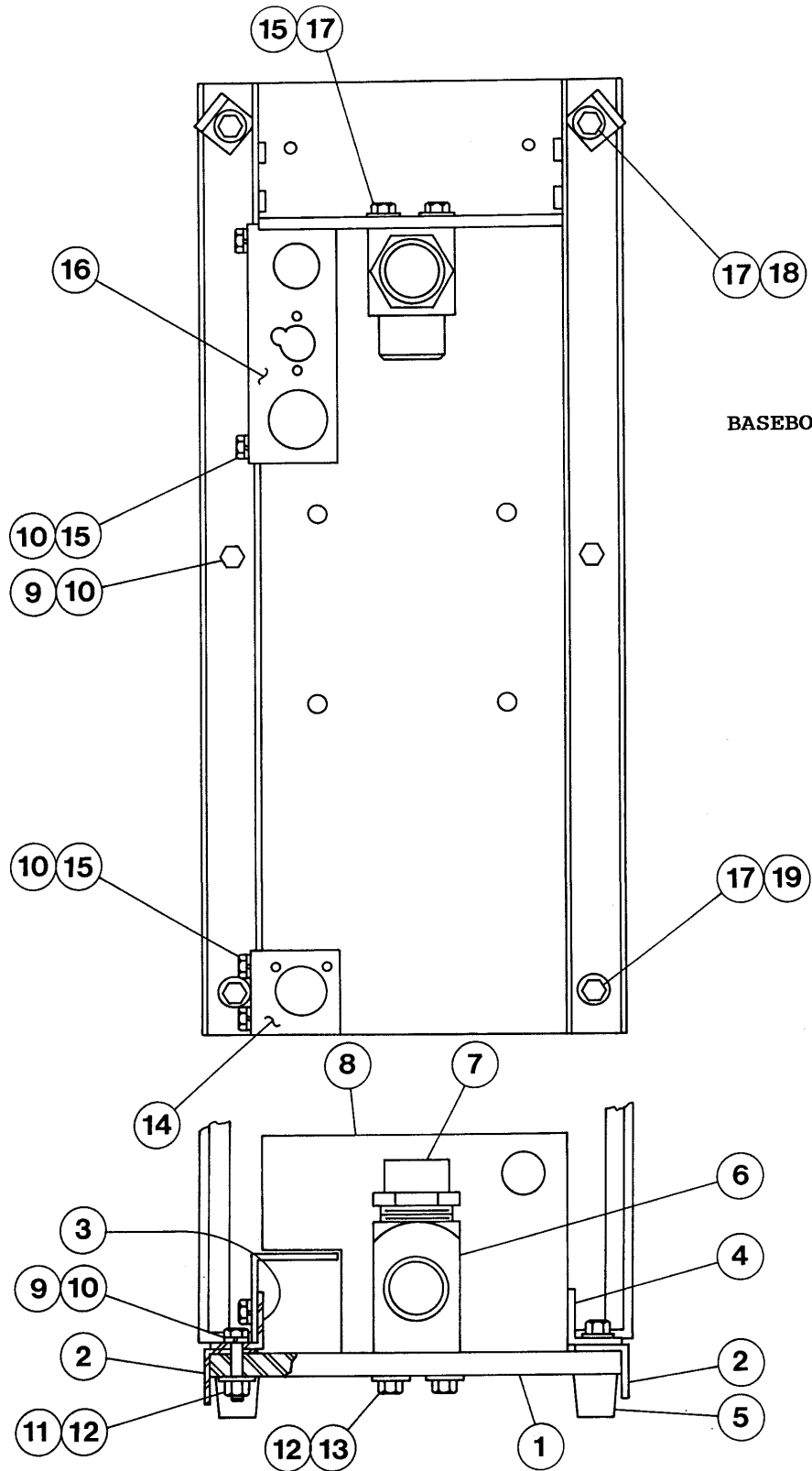

BASEBOARD & RELATED PARTS

ITEM	REQUIRED	PART NUMBER	DESCRIPTION
1	1	5016-2	Baseboard, grey
2	2	5024	Angle Stiffener
3	1	5188	Mounting Angle, 9 holes
4	1	5196	Mounting Angle, 5 holes
5	4	5025	Rubber Foot Assembly
6	1	5017-2	2" Square Adapter Fitting, aluminum
7	1	5030	Adapter Fitting, plastic
8	1	5200	Partition Plate, black
9	2	1000-0125	Hex head capscrew, 1 1/4" long
10	6	1380	Lockwasher
11	2	1200	Hex Nut
12	4	1350	Flatwasher
13	2	1000-0062	Hex Head Capscrew, 1" long
14	1	5192	Mounting Bracket, ball valve
15	6	1000-0062	Hex Head capscrew, 5/8" long
16	1	5183	Control Panel
17	6	1360	SAE Flatwasher
18	2	1000-0175	Hex Head Capscrew, 1 3/4" long
19	2	1000-0150	Hex Head Capscrew, 1 1/2" long

HOPPER GROUP

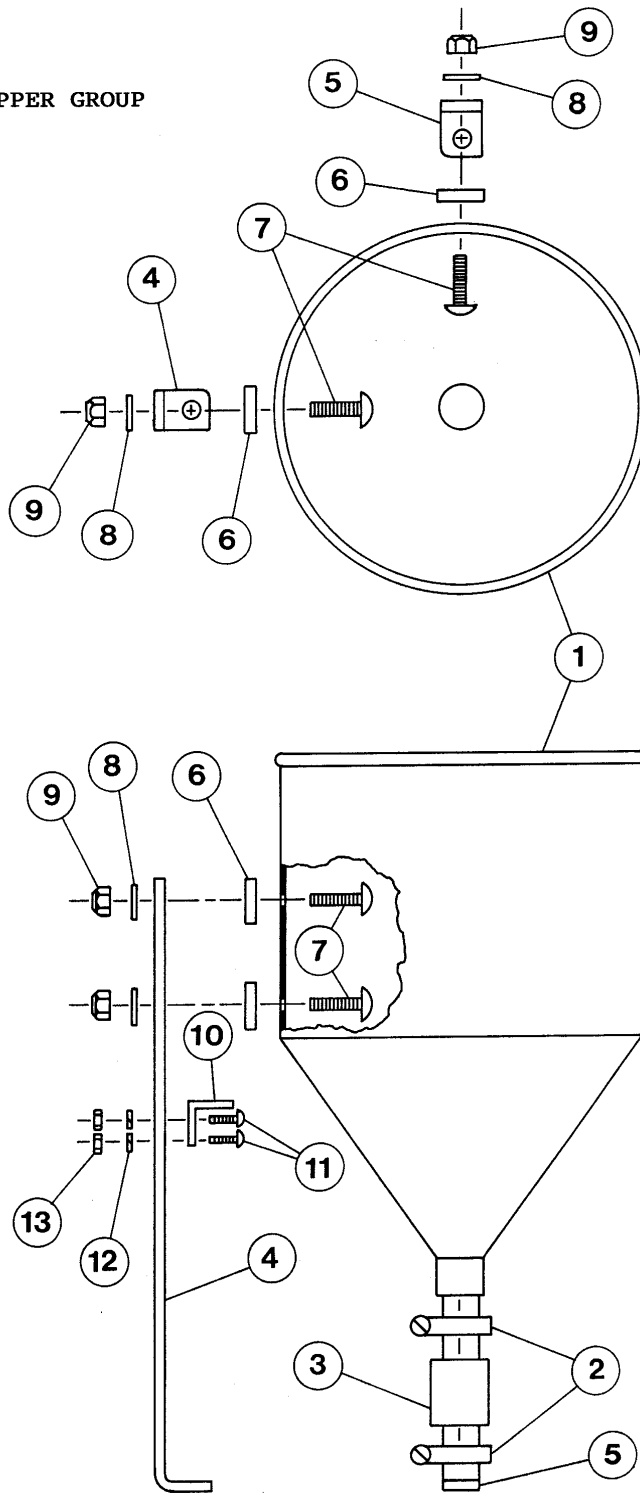

HOPPER GROUP

ITEM	REQUIRED	PART NUMBER	DESCRIPTION
1	1	5028	5/8 cu ft Hopper
2	2	2178	Stainless Hose Clamp
3	1	5022-0175	Connector Hose
4	1	5197	Hopper Support Leg w/mtg holes for filter bracket
5	1	5031	Hopper Support Leg
6	4	5032	Rubber Washer
7	4	1050-0075	Slotted Truss Head Screw, 3/4" long
8	4	1360	SAE Flatwasher
9	4	1220	Esna Hex Nut
10	1	5190	Mounting Bracket, air filter
11	2	1498-0050	Slotted Machine Screw, 1/2" long
12	2	1472	Lockwasher
13	2	1453	Machine Hex Nut



PUMP ASSEMBLY

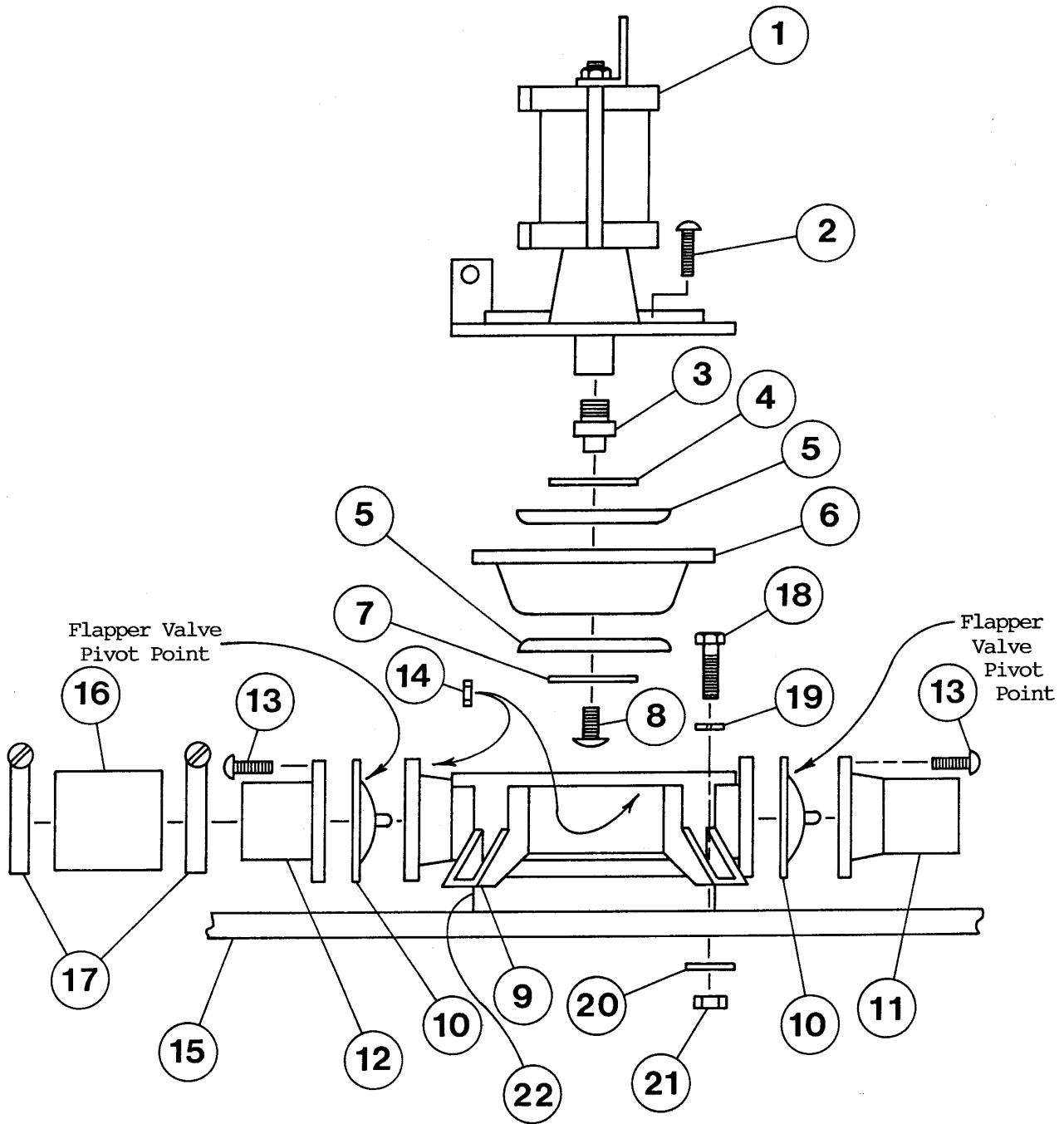

Pump Assembly Part List #5205

ITEM	REQUIRED	PART NUMBER	DESCRIPTION
--	1	5205	Pump Assembly, includes item 1 thru 14
1	1	5204	Cylinder/Clamp Ring Assembly
2	10	1498-0075	Slotted Machine screw, 3/4" long
3	1	5177	Slotted Rod Adapter
4	1	5019-22	Stainless Washer, 1/2" hole
5	2	5019-21	Button
6	1	5019-9	Diaphragm
7	1	5019-29	Stainless Washer, 1/4" hole
8	1	1050-0050	Slotted Truss head Screw, 1/2" long
9	1	5019-12	Pump Body
--	1	5019-35	Pump Body Assembly, includes item 9 thru 14
10	2	5019-15	Flapper Valve
11	1	5019-16	Outlet Flange
12	1	5019-14	Inlet Flange
13	12	1498-0062	Slotted Machine screw, 5/8" long
14	22	1453	Machine Hex Nut
15	1	5016-2	Baseboard, grey
16	1	5022-0250	Connector Hose, 2 1/2" long
17	2	2178	Stainless Hose Clamp
18	4	1000-0100	Hex Head Cap screw, 1" long
19	4	1380	Lock washer
20	4	1350	Flat washer
21	4	1200	Hex Nut
22	1	5157	Spacer Disc

CYLINDER / CLAMP RING ASSEMBLY

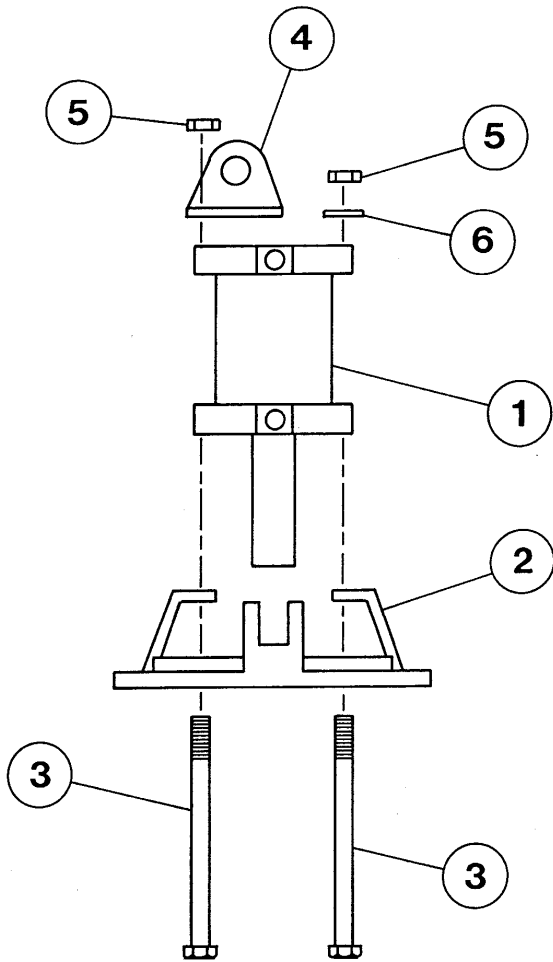

GP-3

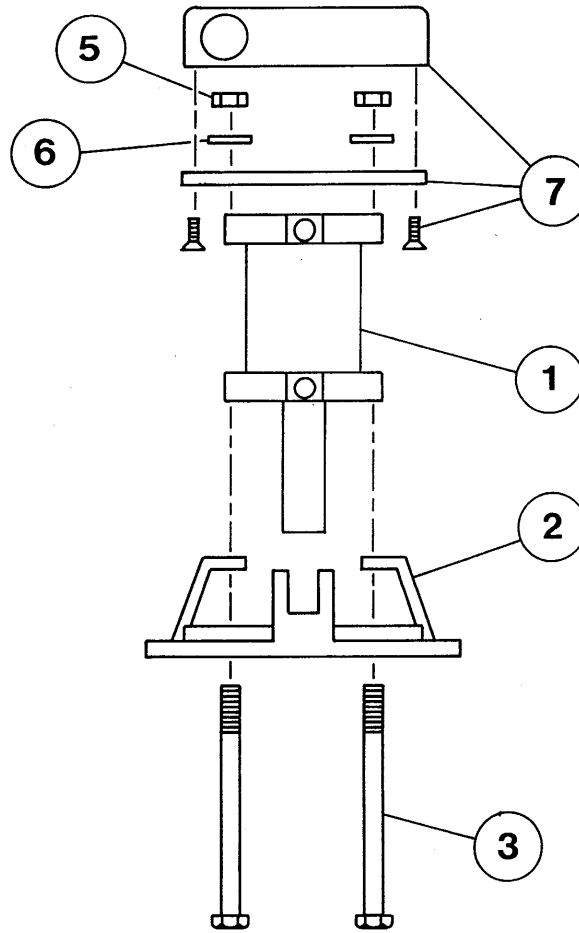

GP-3AR

ITEM	REQ (GP-3)	REQ (GP-3AR)	PART NUMBER	DESCRIPTION
1	1	1	5198	Air Cylinder Assembly
2	1	1	5152	Aluminum Clamp Ring
3	2	2	1000-0400	Hex Head Capscrew, 4" long
4	1	0	5182	Mounting Bracket, stop/start switch
5	2	2	1200	Hex Nut
6	1	2	1360	SAE Flatwasher
7	0	1	5209	Aluminum Control Box Assembly

1½" I.D. PLACEMENT HOSE

<u>Item</u>	<u>Qty</u>	<u>Part Number</u>	<u>Description</u>
1	2	2178	Hose Clamp
2	1	5022-5ft	Placement Hose
3	1	5022-10ft	Placement Hose
4	1	5022-15ft	Placement Hose
5	1	5022-20ft	Placement Hose
6	1	5023	Barrel

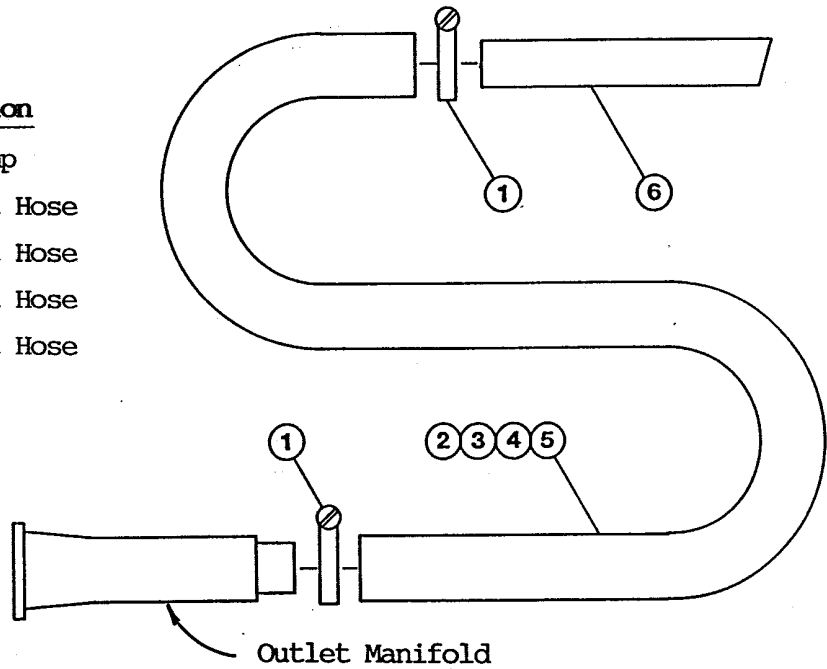

HOSE REDUCER KITS

<u>Item</u>	<u>Qty</u>	<u>3/4" Kit</u>	<u>1" Kit</u>	<u>Description</u>
All	1	5034	5083	Complete Hose Kit
1	2	2178	2178	Hose Clamp
2	1	5022-0250	5022-0250	Sleeve
3	1	5081	5076	Adapter
4	2	2174	2175	Hose Clamp
5	1	5079-6000	5078-6000	Placement Hose
6	1	5130	5131	Nozzle

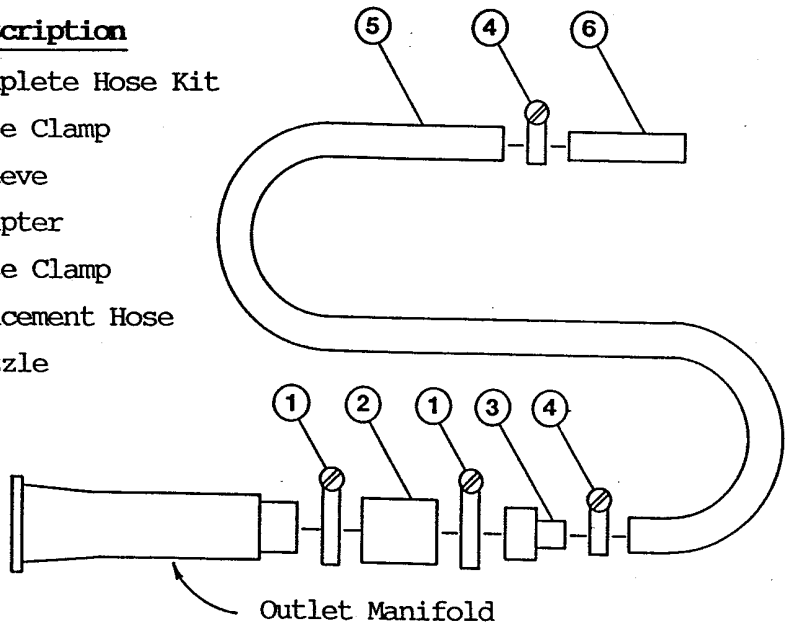

1½" HOSE ENDS & SEAL INSTALLATION

Straight, #5023

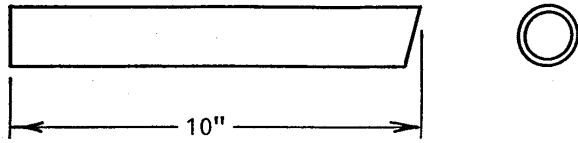

Seal Installation

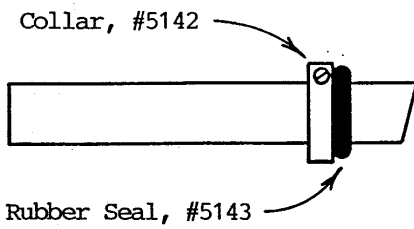

180° Elbow, #5140

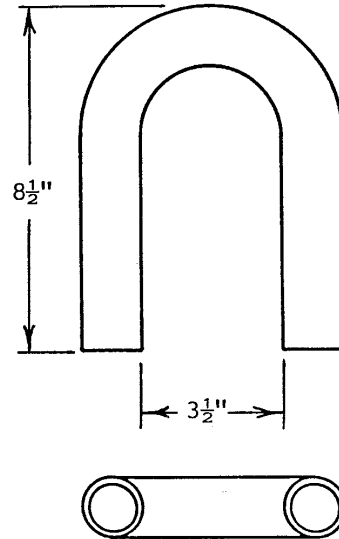

90° Elbow, #5139

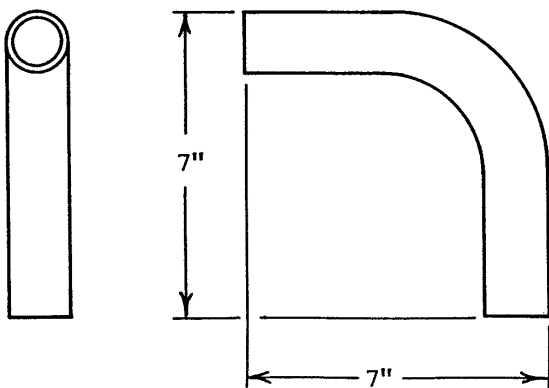

180° Elbow, Short Leg, #5141

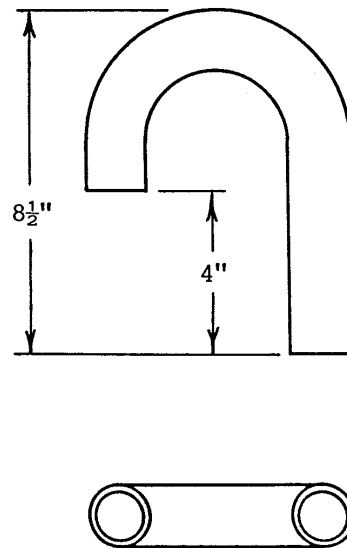

Kenrich Products, Inc.
16327 NE Cameron Blvd. Portland, OR 97203
Mail Address: PO Box 55053, Portland, OR 97238-5053 Phone:
503.281.6190 • Fax: 503.281.6227

<http://www.kenrichproducts.com>